

BSP thread male coupling,

smooth shank,
without or including aluminium clamps



Applications

This Thread Coupling offers possibilities to apply different types of connections.

Advantages

- Reusable safety clamp.

Article No.	ND Thread inch	OD shank mm	OD hose (a) min - max mm	Stock item
Brass BSP Male				
without half shell clamps in aluminium				
5100175	1"	25		1
100030	1" 1/4	32		1
100032	1" 1/2	38		1
100120	2"	50		1
118169	2" 1/2	65		1
5100176	3"	75		1
5100177	4"	100		1
including half shell clamps in aluminium				
117467	1/2"	13	22 - 24	1
113481	3/4"	19	30 - 33	1
117469	1"	19	30 - 33	1
732015	1"	25	36 - 39	1
116599	1" 1/4	25	36 - 39	1
732016	1" 1/4	32	43 - 46	1
116601	1" 1/2	32	43 - 46	1
116602	2"	32	43 - 46	1
731642	1" 1/2	38	50 - 52	1
116604	2"	38	50 - 52	1
113503	1" 1/2	40	53 - 56	1
117470	2"	40	53 - 56	1
731644	2"	50	64 - 67	1
116606	2" 1/2	50	64 - 67	1
113670	2" 1/2	65	78 - 82	1
116608	3"	65	78 - 82	1
731647	3"	75	89 - 93	1
113516	3"	80	94 - 97	1
731648	4"	100	114 - 119	1
117097	4"	100	118 - 122	1

continued on next page

Technical description

Thread coupling: Male BSP, ISO228, thread parallel

Working pressure = 25 bar, except polypropylene = 10 bar.

The hose shank has an annular safety collar and the clamp has a lip which engages behind the collar to prevent hose "blow-off".

Clamp must be selected according to the outside hose diameter.

Complementary information

Stainless steel clamps are available.

This coupling can be delivered, on request, without aluminium clamp to be swaged with serrated ferrule.

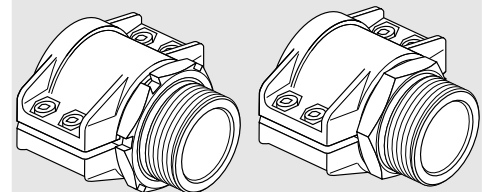
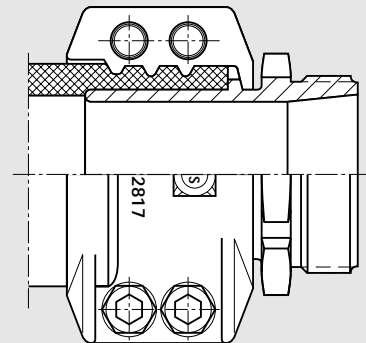

1 = Non stock.

(a) = For clamps for different OD hose : consult us.

04 - 02 - 2002



BSP thread male coupling, smooth shank, without or including aluminium clamps

Couplings for Petroleum and Chemical hoses

Couplings for Petroleum and Chemical hoses

Article No.	ND Thread inch	OD shank mm	OD hose (a) min - max mm	Stock item
<i>continued from previous page</i>				
Tin plated brass BSP male				
including half shell clamps in aluminium				
117671	3/4"	19	30 - 33	•
117468	1"	19	30 - 33	•
116649	1"	25	36 - 39	•
116650	1" 1/4	25	36 - 39	1
116653	1" 1/4	32	43 - 46	•
116654	1" 1/2	32	43 - 46	•
116655	2"	32	43 - 46	1
116658	1" 1/2	38	50 - 52	•
116659	2"	38	50 - 52	•
116662	2"	50	64 - 67	•
116663	2" 1/2	50	64 - 67	•
116666	2" 1/2	65	78 - 82	•
116667	3"	65	78 - 82	•
116671	2" 1/2	75	89 - 93	•
116670	3"	75	89 - 93	•
117098	4"	100	118 - 122	•
Stainless steel 310 Ti BSP Male (b)				
without half shell clamps in aluminium				
100001	3/4"	19	30 - 33	1
100002	1"	25	36 - 39	1
100003	1" 1/4	32	43 - 46	1
100004	1" 1/2	38	50 - 52	1
100005	2"	50	64 - 67	1
100006	2" 1/2	65	78 - 82	1
100007	3"	75	89 - 93	1
5100170	4"	100	118 - 122	1
including half shell clamps in aluminium				
117475	1/2 "	13	22 - 24	1
113504	3/4 "	19	30 - 33	1
113519	1 "	25	36 - 39	1
113660	1 " 1/4	32	43 - 46	1
113662	1 " 1/2	38	50 - 52	1
113664	1 " 1/2	40	53 - 56	1
113666	2 "	50	64 - 67	1
113668	2 " 1/2	65	78 - 82	1
113672	3 "	75	89 - 93	1
113674	3 "	80	94 - 97	1
113675	4 "	100	114 - 119	1
Polypropylene BSP Male without half shell clamps in aluminium				
5100173	1"	25	36 - 39	•
5100174	1" 1/2	38	50 - 52	•
100133	2"	50	64 - 67	•
100134	3"	75	89 - 93	•

This coupling can be delivered, on request, without aluminium clamp to be swaged with serrated ferrule.



• = Stock item.
1 = Non stock.

(a) = For clamps for different OD hose : consult us.

(b) = Stainless steel coupling with internal coated teflon on request

24 - 10 - 2002